

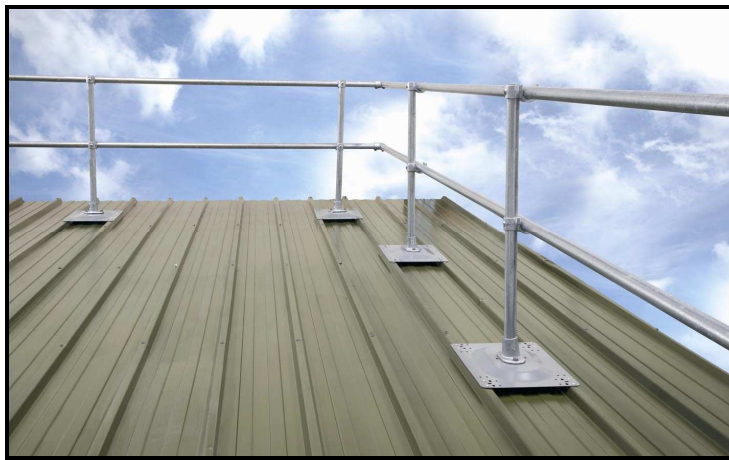

Safety at the highest level



Profile & Standing Seam Metal Roof Edge Protection System Assembly Instructions

COMPLYING WITH THE REQUIREMENTS OF EN 14122 PT3, EN 13374 - 2013 & BS 13700
(CORRECT CONFIGURATIONS REQUIRED)

Kee Safety Ltd
Unit A2 Cradley Business Park
Overend Road
Cradley Heath
West Midlands B64 7DW

Tel.: +44 (0) 1384 632188
Fax: +44 (0) 1384 632192

Contents

Section	Subject	Page
0	Assembling the KeeGuard Topfix System	0-1
0.1	Constructing the KeeGuard Topfix system	0-1

	Amendments	

Assembly of KeeGuard Topfix

0.1 Assembly

Overview

This section is broken down into the following subjects:

Subject	Page
Copyright & Amendment service	0-2
Owner's duty of care	0-2
Personnel requirements	0-3
Installing the KeeGuard Topfix System	0-9



Copyright

This documentation contains information that is protected by copyright. Neither extracts nor the documentation as a whole may be photocopied, reproduced, translated or put onto data carriers without prior approval.

All other rights are reserved.

Amendment service

The documentation is not covered by the amendment service of the manufacturer or its branches. Amendments to this documentation can be made without further notification.

0.2 Owner's duty of care

Contents

In this section, you will be able to familiarise yourself with the tasks and obligations of the owner or employer with regard to working with the KeeGuard Topfix system .

Definition of "Authorised person"

A person is regarded as an authorised person if he/she is commissioned to carry out certain types of work on or using the KeeGuard Topfix system in accordance with instructions.

Protection for personnel

In particular, the owner or employer must ensure that any personal protection equipment required:

- is available for use,
 - is checked regularly.
-

Instruction and training

In particular, the owner or employer must ensure that:

- assembly personnel are instructed in all relevant aspects of health and safety at work and environmental protection before starting work for the first time and also at least once a year after that,
- a full set of legible Assembly instructions are provided to the Installation personnel prior to them commencing work.
- all relevant personnel have familiarised themselves with the contents of these assembly and operating instructions before assembly.

0.3 Personnel requirements

Contents

The manufacturer's requirements regarding assembly, and repair personnel for installing the Fold-shield system are as follows.

Definition of a “Competent Person”

Competent people are those who have sufficient knowledge of the system to be able to assemble or check it on account of their specialist training and experience and are familiar with the relevant regulations, guidelines and generally recognised rules of practice – e.g. Health & Safety Guidelines, accident prevention regulations and suchlike – to such an extent that they can carry out assembly and assess whether or not the system under test is safe to be used.

The owner / employer is responsible for selecting a competent person.

Duties of the assembly personnel

The assembly personnel must carry out the following duties:

- Assemble the system and check to make sure that it is working safely and has no faults.
-

Requirements relating to assembly personnel

Assembly personnel must meet the following requirements in order to be able to carry out their duties:

- They must have received instruction from the owner or employer.
 - They must have sufficient knowledge of the English Language in order to be able to understand these Assembly instructions.
 - They must be free from any disability that may effect their ability to assemble this system or understand these instructions.
-

0.4 Assembling the KeeGuard Topfix System

0.41 Checking the KeeGuard Topfix system's components

Contents

An overview of all the parts which you need in order to assemble the system properly.



Danger!

If some of the parts listed in the parts list or on the delivery note are missing or damaged, then you must replace them with original parts. Contact the manufacturer to obtain these.



Designation and function of the components for standard systems

The KeeGuard Topfix system consists of the following individual components. The exact number of individual components depends on the length and construction of the KeeGuard Topfix system .



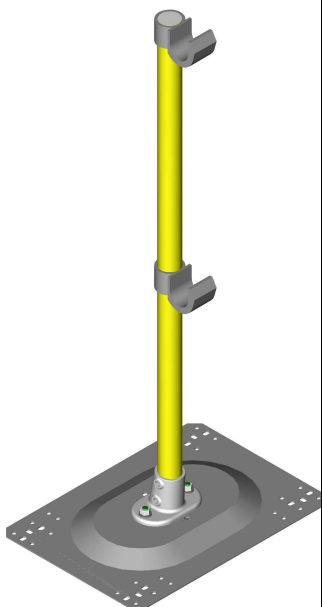

Note: A complete list of all parts and details on the total weight of the fall prevention system are provided with the delivery. The load-bearing capacity of the roof must be equal to or exceed the capacity specified.

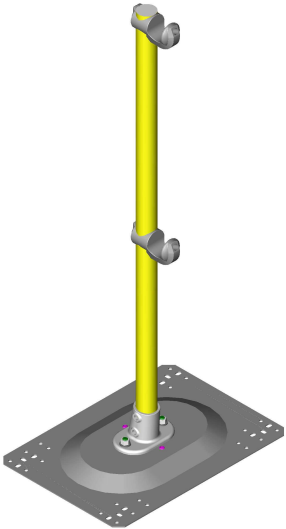
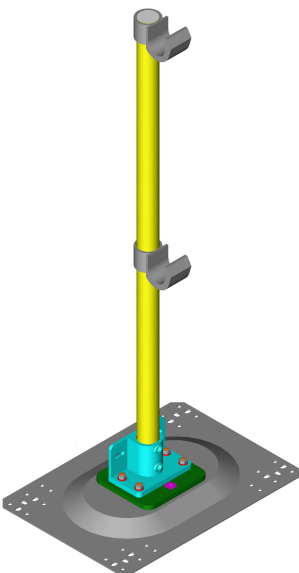

	Designation	Function	Quantity	For total length
1		Vertical posts for the system Diameter = 48.3 mm Thickness = 4mm / 2.9mm Matl. = Galv. Iron & Steel Height = 1100 mm Weight = 15 kg / 13 kg each Fitted with 2 off 135-8 fittings for the top and mid-rails.	4 off / 3 off	6 m
		Can be adjusted up to 11 degrees from the vertical in-board from the edge of the roof. #67 Base can be orientated to suit profile direction of roof.	Refer to section 0.43	> 6 m

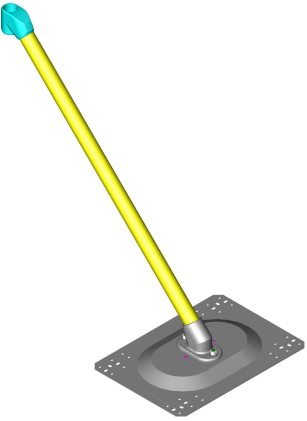
0.41 Checking the KeeGuard Topfix system's components

Designation and function of the components for standard systems

	Designation	Function	Quantity	For total length
2	"KGTF-AL" vertical post 	Vertical posts for the system Diameter = 48.3 mm Thickness = 4.05mm Matl. = Aluminium & Steel Height = 1100 mm Weight = 10 kg each Fitted with 2 off L135-87 fittings for the top and mid-rails. Can be adjusted up to 11 degrees from the vertical in-board from the edge of the roof. #67 Base can be orientated to suit profile direction of roof.	4 off	4.5 m
3	"KGTF49" / " KGTF69 " vertical posts 	Vertical posts for the system Diameter = 48.3 mm Thickness = 4mm / 2.9mm Matl. = Galv. Iron & Steel Height = 1100 mm Weight = 17 kg / 15 kg each Fitted with 2 off 135-8 fittings for the top and mid-rails. #69 Base can be orientated to suit profile direction of roof.	4 off / 3 off	6 m

4	<p>“KGTF-ALB“ Brace for Lite system</p> 	<p>Brace assembly for the Lite system</p> <p>Diameter = 48.3 mm Thickness = 4.05mm Matl. = Aluminium & Steel Diagonal = 1350 mm Weight = 10 kg each Fitted with 1 off L29-8 fitting Can be adjusted up to 60 degrees from the Horizontal.</p> <p>#63 Base can be orientated to suit profile direction of roof.</p>	2 off	4.5 m
5	<p>Top and mid-rails</p> 	<p>Top rail and mid rail form the fall guard</p> <p>Diameter = 42.16 / 48.3 mm Thickness = 3.56 / 3.2mm / 2.9mm Matl. = Aluminium / Galv Steel Length = variable Weight = 1.17 / 4.43 kg / m</p>	1of each @6m	6 m
			As stated	> 6 m
6	<p>77-7 / 77 - 8 plastic stopper</p> 	<p>Caps off the open ends of the tube.</p>	1 off for each tube end	./.
7	<p>L15-7 / 15 - 8 90° elbow joint</p> 	<p>Connects the top and mid rails at an angle of 90°</p>	1 off for each 90° angle	./.
8	<p>LB54-77 / BC53 - 8 in-line hinge joint</p>	<p>Connects the top and mid rails at variable angles of up to 200°.</p>	1 off for each angle	./.

9	L14-7 / 14 - 8 straight tube connector 	Connects the top and mid rails for a straight connection Connection in a top rail should not be in the same bay as the connection in the mid rail. Note: assemble with grub screws pointing downwards	1 off for each straight tube connection	./.
10	61-8 / L61-7 Wall Flange 	Fixing Flange for Wall connection where a suitable structural wall is available	1 Off for each Tube end.	./.
11	Aluminium Toeboard 	Prevents loose debris from being pushed outside of the perimeter the Guarding.	6m Lengths	

Typical KeeGuard Topfix layout diagram 6m Plus Trapazoidal Metal profile Roofs – EN 14122 Pt 3

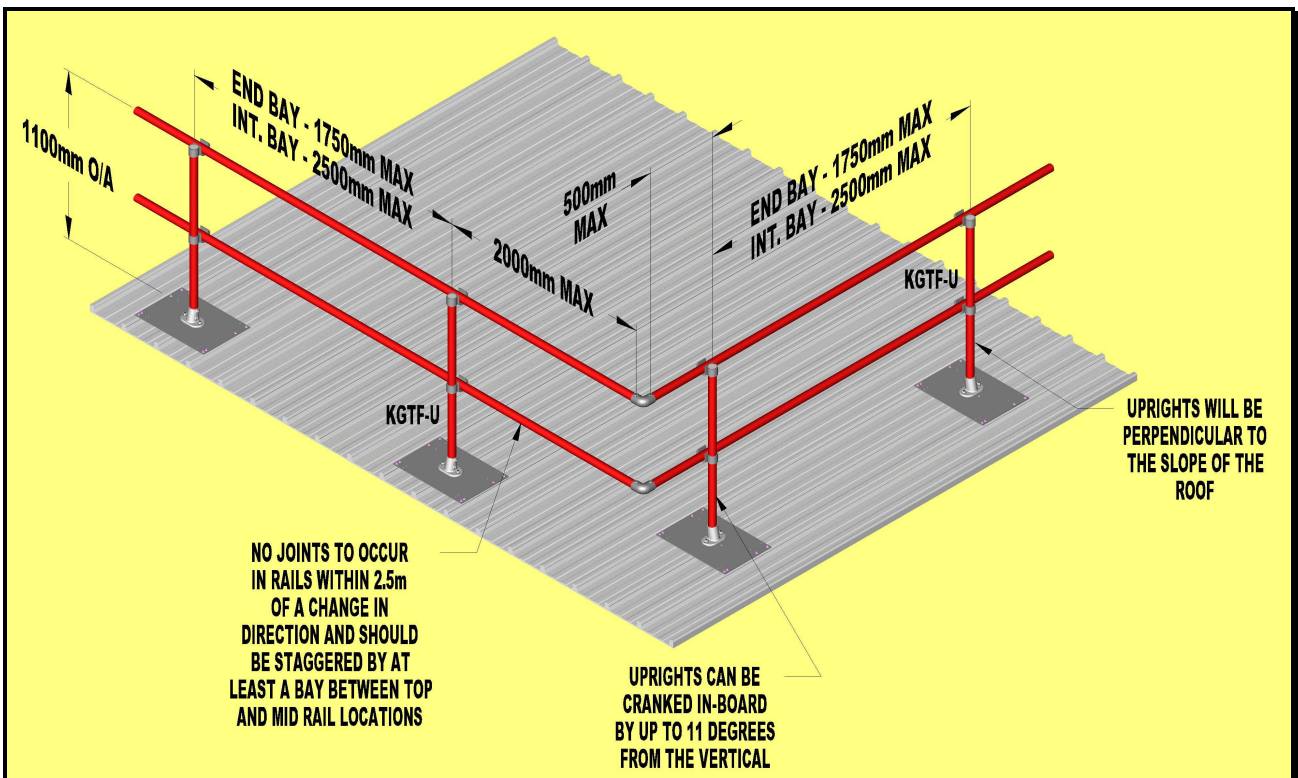

Typical KeeGuard Topfix Lite layout diagram 6m Plus Trapezoidal Metal profile Roofs – EN 14122 Pt 3

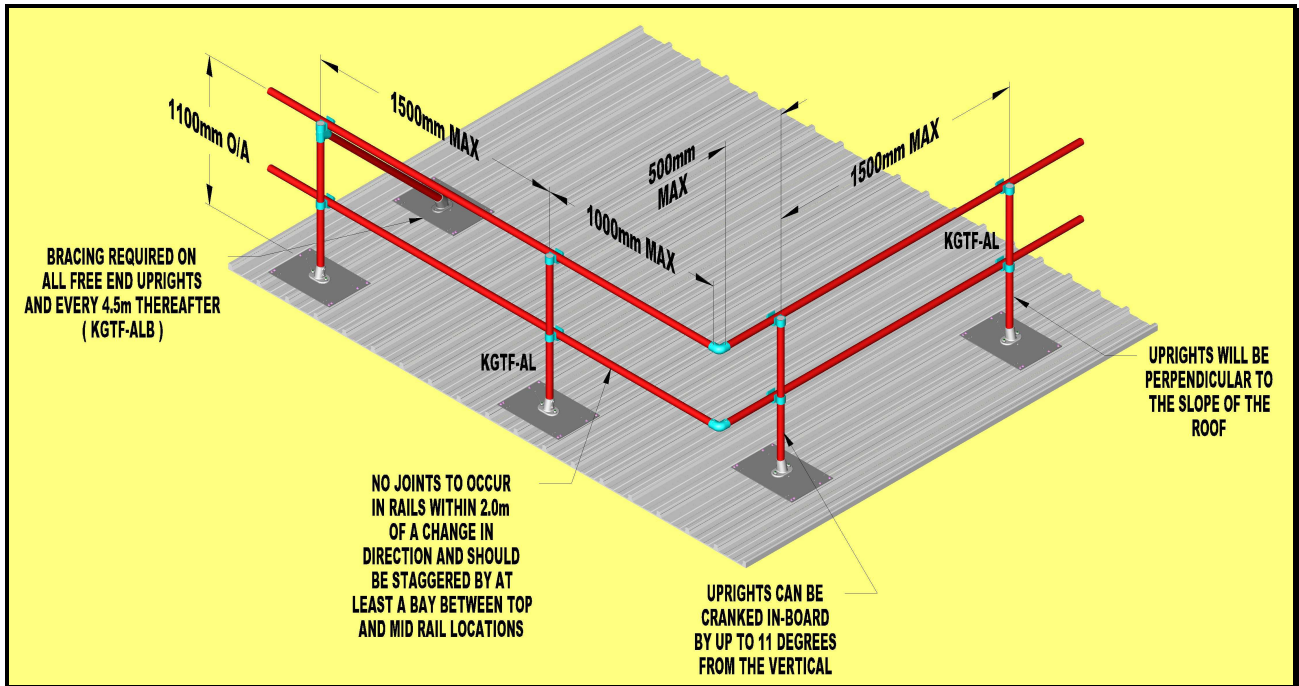

0.42 Selecting a location for installation

Contents

Necessary requirements for the installation site.



Danger!

The condition of the installation site has a decisive influence on the safe functioning of the KeeGuard Topfix system. If the prerequisites are not met at the site of installation, then do not install the system until you have consulted the manufacturer.

- If you cannot be certain of the load-bearing capacity of the roof, then contact a structural engineer before starting construction.

Requirements relating to the installation site

The installation site must meet the following requirements:



Criterion	Requirement
Roof construction	Trapizoidal roofs 0.5mm thk Steel and above and Standing seam profiles are permissible for this installation.
Permissible roof pitch	Max. 45°
Roof surface	The surface of the roof must be free from loose deposits, oil, grease, algae, gravel & accumulated water.
Weather conditions	The roof must be free from snow and ice. If there is the risk of water freezing over during assembly or it starts to snow, then the system must not be installed. KeeGuard Topfix must not be installed if it is very windy.

0.43 Installing the KeeGuard Topfix system

Contents

Description of the standard construction

Danger!

- If you have been sent a detailed installation diagram with the delivery, you must not deviate from this installation diagram as otherwise the safe functioning of the KeeGuard Topfix system cannot be guaranteed.
- The KeeGuard Topfix system must not be installed on roofs which are covered with snow or ice. The roof surface must not become covered with snow or ice during assembly.
- Do not use any non approved or damaged parts for assembly.
- Always use all the parts supplied. If there is insufficient space or there is insufficient load-bearing capacity at the site of installation, then you must not use the KeeGuard Topfix system!
- Competent assembly personnel who must use Personal Protection Equipment to prevent them from falling, may only carry out installation.

Before you start

Before you can start on the installation, you must have carried out the following tasks:

- Check the individual parts are there and not damaged
- Select a suitable location for installation.
- Remove any oil, grease and loose debris from the roof.
- During installation at least two people should be on the roof at all times. Prior to the KeeGuard Topfix Guardrail being erected, all personnel on the roof should ensure they stay at least 2m from the edge of the roof at all times.

Installers should wear a full body safety harness and lanyard, which should be suitably attached to a safe anchor point at all times. The lanyard must be short enough to prevent installers reaching the edge of the roof (so that they are never in a position where they may fall from the roof).

- The above recommendations are made in addition to the following:
Installers and users must comply with all relevant health and safety regulations. In the U.K., particular attention should be drawn to the following H.S.E. publications: -
 - i) Construction summary sheet – Safety in roofwork.
 - ii) Construction sheet No 21 – Work on flat roofs: - Protection against falls.

U.K. based installers / users may obtain copies of the above publications – free of charge – from their Health and Safety Executive area office.

Tools required

You will need the following in order to install the fall prevention system:

Tool List

- Ratchet
- 5/16" Hexagon Bit Socket
- 10mm A/F Socket
- 19mm A/F Socket
- 19mm A/F Spanner
- Torque Wrench
- Long Arm Rivet Gun to suit 6.4mm (¼") Dia. Blind Rivets.
- Electric / battery powered Drill
- Ø 6.7mm HSS Drill Bit
- Measuring Device (tape measure, laser measure, etc.)
- Permanent Marker Pen
- Scissors / Knife (for cutting sealing strip)

Preliminary remarks relating to the installation of the KeeGuard Topfix system for runs less than 6 m long

You must note the following points if you are intending to install a run in the above situation :

- You must contact our technical service department on

tel. 0044 1384 632188

if you intend to install a system with a total length of less than 6 m.

Preliminary remarks on the use of tube connectors (Fittings)

Only use the tube connectors as follows:

- You must use the L14-7 / 14 - 8 straight tube connectors for straight connections.
 - You must use the L15-7 / 15 - 8 90° tube connectors for 90° elbow connections.
 - You must use the LB54-77 / BC53 - 88 hinge joint for angle connections adjustable through 200°.
-

Installing the 6m PLUS KeeGuard Topfix System to EN 14122 PT 3.

Step 1: Positioning the Uprights

Install the assembled vertical posts. Start with the KGTF-U vertical post at the beginning of the section of railing followed by a second KGTF-U at no more than 1.75m from the first KGTF-U. Subsequently add KGTF-U assemblies thereafter.

You must note the following points during assembly:

- At the beginning and end of the section of railing, there must always be a KGTF-U vertical post if it is not possible to have a wall connection.
- The maximum permissible distance between adjacent Intermediate vertical posts is 2.5 m (see the installation diagram if supplied).
- The maximum permissible distance between a vertical post – before or after angle connections is 500 mm (see installation diagram if supplied).
- Align the baseplate so that at least eight of the round 9mm diameter holes are aligned with the crests of the sheeting. See Figure below for available profile.
- Cover these holes on the underneath of the Baseplate with the recommended double sided sealing strip. Remove backing tape before going onto next stage.
- Align the baseplate holes with the crests of the roof
- Press the Baseplate down into position.
- Use a drill of diameter 6.7mm to drill through identified holes (a minimum of eight in total) i.e. 2 fixings per corner.
 - Note: Roof Insulation may protrude through the holes during the drilling process. This can be pushed back into the holes.
- Fix the recommended Kee Safety rivets into the drilled holes.
 - **Kee Safety can only recommend the rivets supplied by Kee Safety.**
 - Follow the guidelines given with the Rivet Installation Tool.

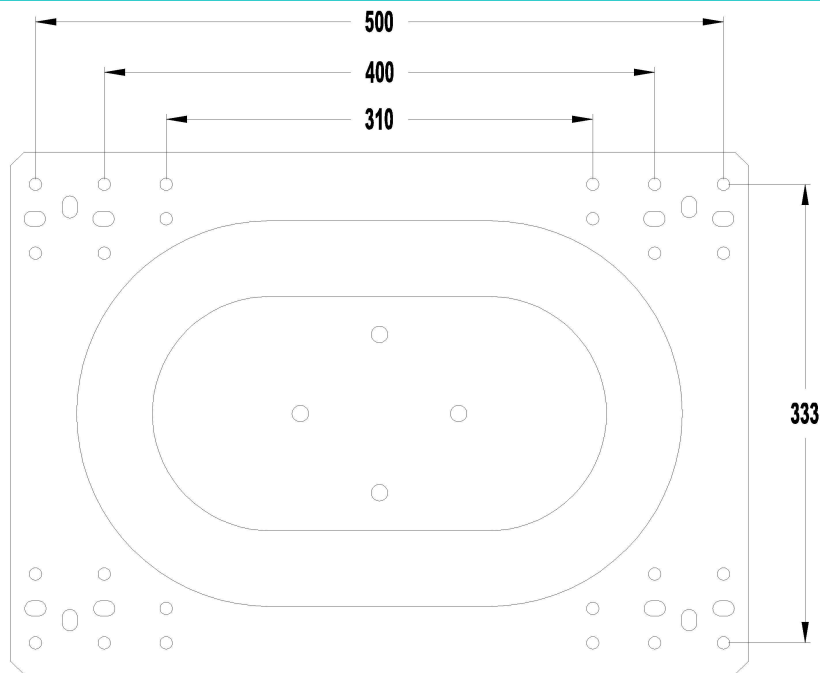

Figure - Baseplate to suit Trapezoidal Roof with 310mm, 333mm, 400mm & 500mm profile

Step 2: Fitting the top and mid rails

Fit the top and mid rails between the vertical posts as shown in the diagram. To do this, you must drop the rail into the open cup fitting on each vertical post.

You must note the following points during assembly:

- For runs greater than 6 metres each section of the top and mid rails must be at least 5.2 m long (based on maximum 2.5m bay size). Shorter sections of tube are only permissible for sections less than 6m.
- The top and mid rails may only be connected together using 14 - 8, 15 - 8, 19 - 8, BC53 - 88 and 55 - 8 fittings. Connections should not be made within 2.5m of an end upright or change in direction.
- Ensure the tube connector fittings for the top and mid rail are staggered by at least one bay apart to ensure the system is structurally rigid and can meet the deflection requirements of EN 14122 Pt 3.

Step 3: Tightening the adjusting screws

Finally, tighten all the adjusting screws by applying a tightening torque of 39 Nm. Holes not used in the Baseplate for securing the #67-8 Base should be plugged with M12 ST/ST Screws.

Terminating the run

The following terminations can be used at the ends according to the structural conditions in each case:

Free end with 77 - 8 plastic stopper

Seal off the open ends of the top and mid rails using a 77 - 8 plastic stopper on each end.

Free end with D-shaped bend

Connect the open ends (max. projection 500 mm) of the top and mid rails using two 15 - 8, 90° fittings and a short vertical tube to form a D-shaped bend. There must be no joint in the rails forming the D.

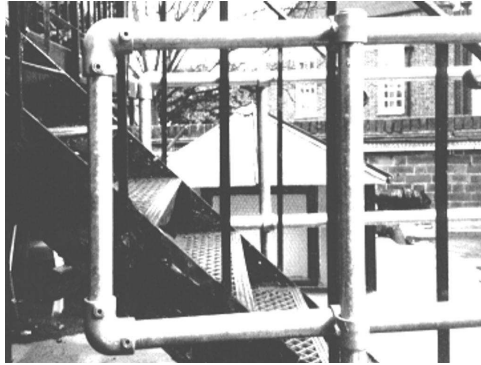

Wall connection

Fit a 61-8 wall flange to the end of each rail and fix each wall flange to the existing brickwork with appropriate fixings. Make sure that the distance between the wall and the next vertical post does not exceed a maximum of 2 m!

It will depend on the brickwork as to which fixings you need to use. Consult a specialist if you need help selecting the fixings.



Installing the 6m PLUS KeeGuard Topfix System to EN 13374 - 2013 & BS 13700.

Step 1: Positioning the Uprights

Install the assembled vertical posts. Start with the KGTF29 vertical post at the beginning of the section of railing followed by a second KGTF29 at no more than 3m from the first KGTF29. Subsequently add KGTF29 assemblies thereafter.

You must note the following points during assembly:

- At the beginning and end of the section of railing, there must always be a KGTF29 vertical post if it is not possible to have a wall connection.
- The maximum permissible distance between adjacent Intermediate vertical posts is 3m (see the installation diagram supplied).

- The maximum permissible distance between a vertical post – before or after angle connections is 500 mm (see installation diagram supplied).
- Align the baseplate so that at least eight of the round 9mm diameter holes are aligned with the crests of the sheeting.
- Cover these holes on the underneath of the Baseplate with the recommended double sided sealing strip. Remove backing tape before going onto next stage.
- Align the baseplate holes with the crests of the roof
- Press the Baseplate down into position.
- Use a drill of diameter 6.7mm to drill through identified holes (a minimum of eight in total) i.e. 2 fixings per corner.
 - Note: Roof Insulation may protrude through the holes during the drilling process. This can be pushed back into the holes.
- Fix the recommended Kee Safety rivets into the drilled holes.
 - **Kee Safety can only recommend the rivets supplied by Kee Safety.**
 - Follow the guidelines given with the Rivet Installation Tool.

Step 2: Fitting the top and mid rails

Fit the top and mid rails between the vertical posts as shown in the diagram. To do this, you must drop the rail into the open cup fitting on each vertical post.

You must note the following points during assembly:

- For runs greater than 6 metres each section of the top and mid rails must be at least 3.2 m long (based on maximum 3m bay size). Shorter sections of tube are only permissible for sections less than 6m.
- The top and mid rails may only be connected together using 14 - 8, 15 - 8, 19 - 8, BC53 – 88 and 55 – 8 fittings. Connections should not be made within 3m of an end upright or change in direction.
- Ensure the tube connector fittings for the top and mid rail are staggered by at least one bay apart to ensure the system is structurally rigid and can meet the deflection requirements of EN 13374 - 2013 and BS 13700.

Step 3: Tightening the adjusting screws

Finally, tighten all the adjusting screws by applying a tightening torque of 39 Nm. Holes not used in the Baseplate for securing the #67-8 Base should be plugged with M12 ST/ST Screws.

Terminating the run

The terminations advised for the above system can be used at the ends according to the same structural conditions in each case.

Installing the 6m PLUS KeeGuard Topfix Standing Seam System to EN 14122 Pt3.

Step 1: Positioning the Uprights

Install the assembled vertical posts. Start with the KGTF-U vertical post at the beginning of the section of railing followed by a second KGTF-U at no more than 2m from the first KGTF-U. Subsequently add KGTF-U assemblies thereafter.

You must note the following points during assembly:

- At the beginning and end of the section of railing, there must always be a KGTF-U vertical post if it is not possible to have a wall connection.
- The maximum permissible distance between adjacent Intermediate vertical posts is 2m (see the installation diagram supplied).
- The maximum permissible distance between a vertical post – before or after angle connections is 500 mm (see installation diagram supplied).
- Align the baseplate so that at least Four of the slotted holes are aligned with the crests of the sheeting. Mark the aligned slots with a marker pen.
- Loosely fit four off of the standing seam clamps to the underside of the KGTF-U Base plate in the relevant marked slots in the corresponding corners.

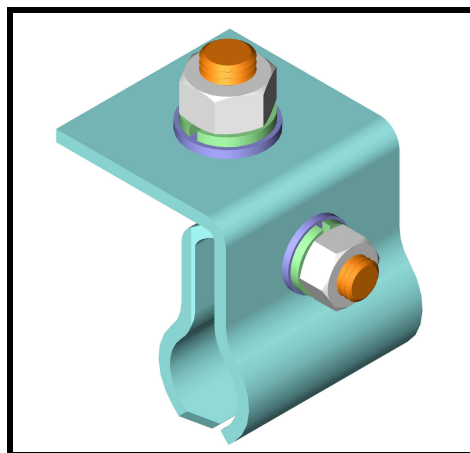

- Ensure that the clamping screw and nut is fully backed off to allow the clamp to fit over the seam.
- Place the upright onto the standing seams.
- Press into position and hold
- Tighten the clamping screws to the recommend torque of 15 Nm.

Step 2: Fitting the top and mid rails

Fit the top and mid rails between the vertical posts as shown in the diagram. To do this, you must drop the rail into the open cup fitting on each vertical post.

You must note the following points during assembly:

- For runs greater than 6 metres each section of the top and mid rails must be at least 6.4 m long (based on maximum 2m bay size). Shorter sections of tube are only permissible for sections less than 6m.
- The top and mid rails may only be connected together using 14 - 8, 15 - 8, 19 - 8, BC53 – 88 and 55 – 8 fittings. Connections should not be made within 2.5m of an end upright or change in direction.
- Ensure the tube connector fittings for the top and mid rail are staggered by at least one bay apart to ensure the system is structurally rigid and can meet the deflection requirements of EN 13374 and BS 13700

Step 3: Tightening the adjusting screws

Finally, tighten all the adjusting screws by applying a tightening torque of 39 Nm. Holes not used in the Baseplate for securing the #67-8 Base should be plugged with M12 ST/ST Screws.

Terminating the run

The terminations advised for the standard system can be used at the ends according to the same structural conditions in each case.

Installing the 6m PLUS KeeGuard Topfix Lite System to EN 14122 PT 3.

Step 1: Positioning the Uprights & Braces

Install the assembled vertical posts. Start with the KGTF-AL vertical post and KGTF-ALB Brace Assembly at the beginning of the section of railing followed by a second KGTF-AL at no more than 1.5m from the first KGTF-AL. Subsequently add KGTF-AL assemblies thereafter and KGTF-ALB Brace Assemblies every 4.5m.

You must note the following points during assembly:

- At the beginning and end of the section of railing, there must always be a KGTF-AL Vertical Post and KGTF-ALB Brace Assembly if it is not possible to have a wall connection.
- The maximum permissible distance between adjacent Intermediate vertical posts is 1.5 m (see the installation diagram if supplied).
- The maximum permissible distance between a vertical post – before or after angle connections is 500 mm (see installation diagram if supplied).
- Align the baseplate so that at least eight of the round 9mm diameter holes are aligned with the crests of the sheeting. See Figure below for available profile.
- Cover these holes on the underneath of the Baseplate with the recommended double sided sealing strip. Remove backing tape before going onto next stage.
- Align the baseplate holes with the crests of the roof
- Press the Baseplate down into position.
- Use a drill of diameter 6.7mm to drill through identified holes (a minimum of eight in total) i.e. 2 fixings per corner.
 - Note: Roof Insulation may protrude through the holes during the drilling process. This can be pushed back into the holes.
- Fix the recommended Kee Safety rivets into the drilled holes.
 - **Kee Safety can only recommend the rivets supplied by Kee Safety.**
 - Follow the guidelines given with the Rivet Installation Tool.

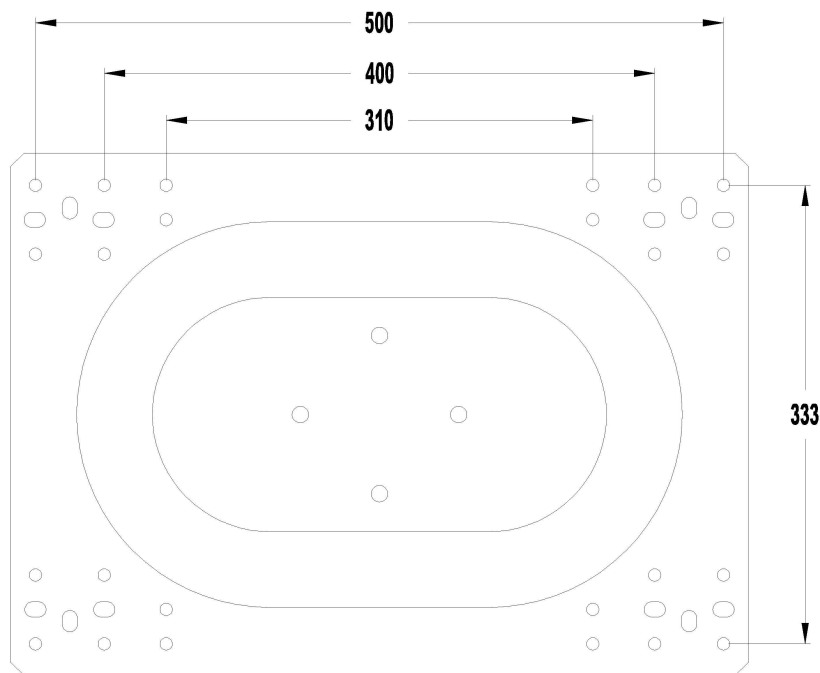

Figure - Baseplate to suit Trapezoidal Roof with 310mm, 333mm, 400mm & 500mm profile

Step 2: Fitting the top and mid rails

Fit the top and mid rails between the vertical posts as shown in the diagram. To do this, you must drop the rail into the open cup fitting on each vertical post.

You must note the following points during assembly:

- For runs greater than 6 metres each section of the top and mid rails must be at least 4.7 m long (based on maximum 1.5m bay size). Shorter sections of tube are only permissible for sections less than 6m.
- The top and mid rails may only be connected together using L14 - 7, L15 - 7, L19 - 77, LB54 - 77 fittings. Connections should not be made within 2.0m of an end upright or change in direction.
- Ensure the tube connector fittings for the top and mid rail are staggered by at least one bay apart to ensure the system is structurally rigid and can meet the deflection requirements of EN 14122 Pt 3.

Step 3: Tightening the adjusting screws

Finally, tighten all the adjusting screws by applying a tightening torque of 39 Nm. Holes not used in the Baseplate for securing the #63-8 / #67-8 Base should be plugged with M12 ST/ST Screws.

Terminating the run

The following terminations can be used at the ends according to the structural conditions in each case:

Free end with 77 - 7 plastic stopper

Seal off the open ends of the top and mid rails using a 77 - 7 plastic stopper on each end.

Free end with D-shaped bend

Connect the open ends (max. projection 500 mm) of the top and mid rails using two L15 - 7, 90° fittings and a short vertical tube to form a D-shaped bend. There must be no joint in the rails forming the D.

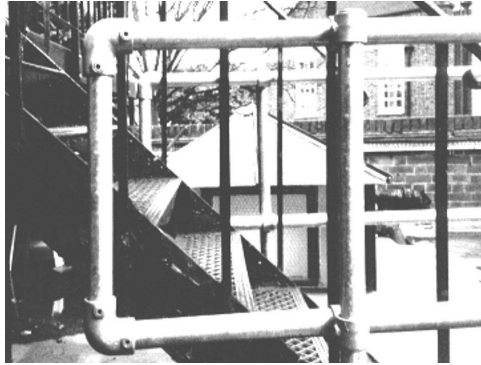

Wall connection

Fit a L61-7 wall flange to the end of each rail and fix each wall flange to the existing brickwork with appropriate fixings. Make sure that the distance between the wall and the next vertical post does not exceed a maximum of 1.5 m!

It will depend on the brickwork as to which fixings you need to use. Consult a specialist if you need help selecting the fixings.



Installing the 6m PLUS KeeGuard Topfix Lite Standing Seam System to EN 14122 Pt3.

Step 1: Positioning the Uprights & Braces

Install the assembled vertical posts. Start with the KGTF-AL vertical post and KGTF-ALB Brace Assembly at the beginning of the section of railing followed by a second KGTF-AL at no more than 1.5m from the first KGTF-AL. Subsequently add KGTF-AL assemblies thereafter and KGTF-ALB Brace Assemblies every 4.5m.

You must note the following points during assembly:

- At the beginning and end of the section of railing, there must always be a KGTF-AL Vertical Post and KGTF-ALB Brace Assembly if it is not possible to have a wall connection.
- The maximum permissible distance between adjacent Intermediate vertical posts is 1.5 m (see the installation diagram if supplied).
- The maximum permissible distance between a vertical post – before or after angle connections is 500 mm (see installation diagram if supplied).
- Align the baseplates so that at least Four of the slotted holes are aligned with the crests of the sheeting. Mark the aligned slots with a marker pen.
- Loosely fit four off of the standing seam clamps to the underside of the KGTF-AL & KGTF-ALB Base plates in the relevant marked slots in the corresponding corners.

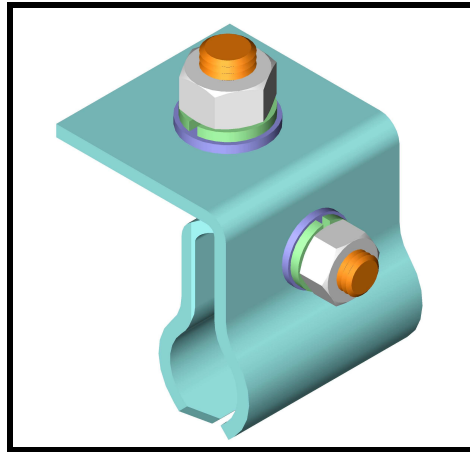

- Ensure that the clamping screw and nut is fully backed off to allow the clamp to fit over the seam.
- Place the Upright / Brace onto the standing seams.
- Press into position and hold
- Tighten the clamping screws to the recommend torque of 15 Nm.

Step 2: Fitting the top and mid rails

Fit the top and mid rails between the vertical posts as shown in the diagram. To do this, you must drop the rail into the open cup fitting on each vertical post.

You must note the following points during assembly:

- For runs greater than 6 metres each section of the top and mid rails must be at least 4.7 m long (based on maximum 1.5m bay size). Shorter sections of tube are only permissible for sections less than 6m.
- The top and mid rails may only be connected together using 14 - 8, 15 - 8, 19 - 8, BC53 – 88 and 55 – 8 fittings. Connections should not be made within 2.0m of an end upright or change in direction.
- Ensure the tube connector fittings for the top and mid rail are staggered by at least one bay apart to ensure the system is structurally rigid and can meet the deflection requirements of EN 14122 pt 3.



Step 3: Tightening the adjusting screws

Finally, tighten all the adjusting screws by applying a tightening torque of 39 Nm. Holes not used in the Baseplates for securing the #63-8 / #67-8 Bases should be plugged with M12 ST/ST Screws.

Terminating the run

The terminations advised for the standard system can be used at the ends according to the same structural conditions in each case.

ISSUE No.	AMENDMENTS MADE	DATE MODIFIED
1	First Issue	21 st June 2010
2	Page 0 - 13 - Standing Seam clamp details changed	21 st July 2010
3	' Standing Seam ' option added to Front Cover Page 0 - 9 - ' IF ' added to sixth and seventh bullet points.	23 rd July 2010
4	Page 0 - 9 - Bullet point 12 changed quantity of fixings required Page 0 - 10 - Step 3 changed. Page 0 - 11 - Bullet point 8 changed quantity of fixings required Page 0 - 12 - Step 3 changed Page 0 - 13 - Step 3 changed	19 th August 2010
5	Cover - Picture added Page 0 - 6 - Picture revised Page 0 - 10 - Picture revised	5 th October 2010
6	Cover - Rev No. Page 0 - 1 - Page numbers changed Page 0 - 5 - Items 2 & 3 Added Page 0 - 6 - Items 4 to 8 KeeLite options added Page 0 - 7 - Topfix Lite option added Page 0 - 10 - Bullet points 14, 15 & 16 Changed Page 0 - 15 - Topfix Lite Option added	18 th November 2010
7	Cover - Rev No. Page 0 - 4 - Post Designation changed. Page 0 - 5 - Post & Brace designations changed. Page 0 - 7 - Both images revised to include new designations. Page 0 - 10 - Step 1 altered with new designations. Page 0 - 12 - Step 1 altered with new designations. Page 0 - 13 - Step 1 altered with new designations. Page 0 - 15 - Step 1 altered with new designations.	19 th January 2011
8	Cover - Rev No. Page 0 - 6 - Item 9 added Page 0 - 12 - Wall connection added Page 0 - 17 - Wall connection added	17 th March 2011
9	Cover - Rev No. Pages 0 - 18 & 0 - 19 - Added	7 th June 2011
10	Cover - Rev No, EN13374 Year, Address, Telephone Numbers & Copyright year Page 0 - 4 - ITEM 1 Details amended Page 0 - 13 - Steps 1 & 2 Amended Page 0 - 14 - EN 13374 removed from title of Standing Seam Installation	25 th March 2013
11	Cover - Rev No Page 0 - 4 - ITEM 1 Details amended Page 0 - 5 - ITEM 3 Added Page 0 - 7 - ITEM 11 Added Page 0 - 10 - Telephone Number amended	16 th October 2013

